

HOPPERTOP

Weigh Hopper Venting Filter

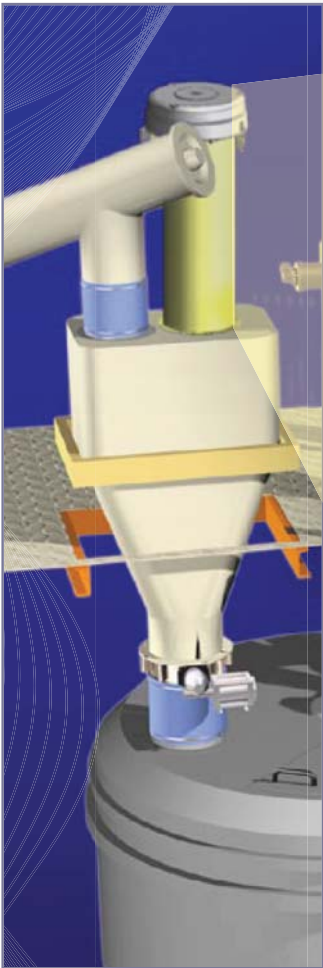

SMALL FOOTPRINT

EASY TO ASSEMBLE

MAINTENANCE-FRIENDLY

PATENTED

HOPPERTOP

Weigh Hopper Venting

THE TOP CHOICE FOR HOPPER VENTING IN CONCRETE PLANTS

HOPPERTOP is a COMPACT air filter specially developed for venting of mechanically loaded cement weigh hoppers in concrete plants.

Dust which is separated from the air flow by a single WAM® cartridge filter element drops back into the hopper after an integrated automatic reverse air jet cleaning system inside the weather protection cover has removed the dust particles from the filter elements.

Features

- Compact dimensions
- Stainless steel design
- Hinged cover
- Approved cartridge quality
- Cartridge removal without tools
- High-performance filter cartridge

Overall Dimensions

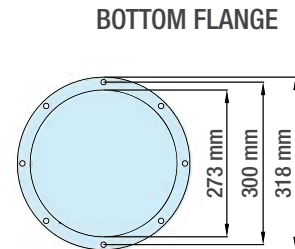
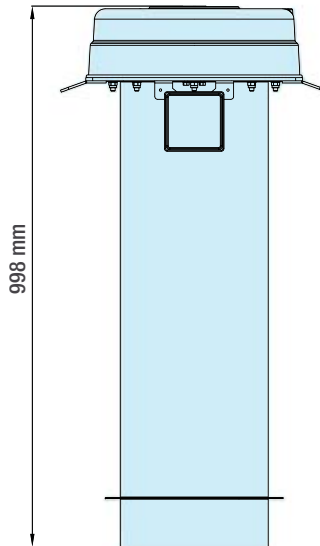
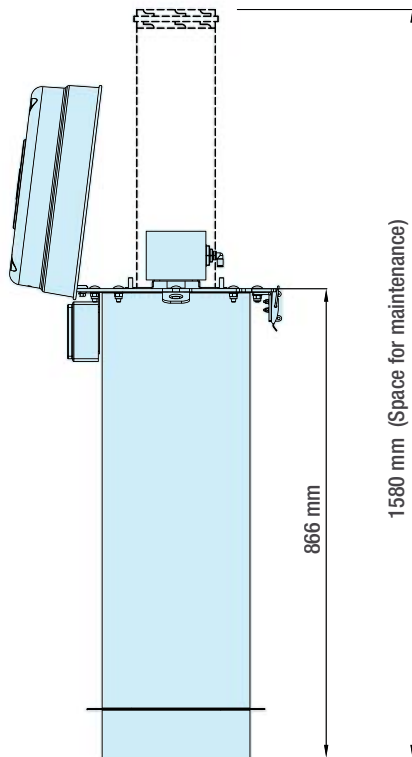

MODEL	TYPE	FILTER SURFACE (m ²)
HTP10001V	VENTING	1
HTP10001R	TOP CONNECTION	1

Benefits



Maintenance height:
870 mm

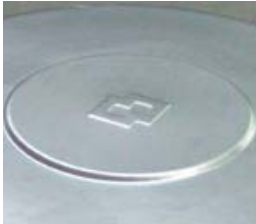

Long durability thanks
to stainless steel
construction



Easy maintenance
thanks to hinged top
cover and cartridge
removal without tools



Ø 273 mm



Small footprint and
easy to handle



Durable thanks to
wide pleat cartridge
geometry



Compliance with
Dust Emission laws
due to high-efficiency
filter media

Accessories

Cover for external pipe connection

- Required for dust emission sampling connection
- Robust powder-coated steel cover
- Easy to fit to existing venting versions

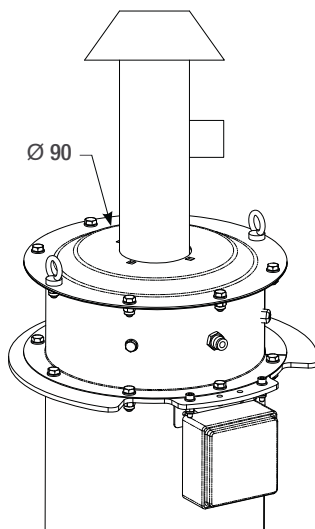

Electronic Differential Pressure Meter



- Filter DP continuously measured and displayed on 3 digit display;
- Cleaning activation with pressure threshold;
- Alarm pressure can switch on external device;
- 4-20 mA exit to read DP value on plant PLC;
- Possible to install on existing filters.

Applications



Typical Application:

- Venting of mechanically filled weigh hoppers in concrete batching plants

